

**PLEASE CHECK WWW.MOLEX.COM FOR LATEST PART INFORMATION**

**Part Number:** [0039012061](#)  
**Status:** **Active**  
**Overview:** [minifit\\_jr](#)  
**Description:** 4.20mm (.165") Pitch Mini-Fit Jr.™ Plug Housing, Dual Row, with and without Panel Mount Ears, UL 94V-2, Panel Mount, 6 Circuits

**Documents:**

[3D Model](#) [Product Specification PS-5556-001 \(PDF\)](#)  
[Drawing \(PDF\)](#) [RoHS Certificate of Compliance \(PDF\)](#)

**Agency Certification**

CSA	LR19980
TUV	R72081037
UL	E29179

**General**

Product Family	Crimp Housings
Series	<a href="#">5559</a>
Comments	Current = 13A max. per circuit when header is mated to a receptacle loaded with <a href="#">45750</a> series terminals crimped to 16 AWG wire. . See Molex product specification PS-45750-001 for additional current de-rating information.. Not for use with Strain Relief
MolexKits	Yes
Overview	<a href="#">minifit_jr</a>
Product Name	Mini-Fit Jr.™

**Physical**

Breakaway	No
Circuits (maximum)	6
Color - Resin	Natural
Flammability	94V-2
Gender	Male
Glow-Wire Compliant	No
Material - Resin	Nylon
Number of Rows	2
Packaging Type	Bag
Panel Mount	Yes
Pitch - Mating Interface (in)	0.165 In
Pitch - Mating Interface (mm)	4.20 mm
Pitch - Term. Interface (in)	0.165 In
Pitch - Term. Interface (mm)	4.20 mm
Polarized to Mating Part	Yes
Stackable	No
Temperature Range - Operating	-40°C to +105°C

**Electrical**

Current - Maximum per Contact	13A
-------------------------------	-----

**Material Info**

Old Part Number	5559-06P
-----------------	----------

**Reference - Drawing Numbers**

Packaging Specification	SPK-5559-001
Product Specification	PS-5556-001
Sales Drawing	SD-5559-NP
Test Summary	TS-5556-002



image - Reference only

**EU RoHS**

**ELV and RoHS Compliant**  
**REACH SVHC Contains SVHC: No**  
**Halogen-Free Status**

**China RoHS**



**Need more information on product environmental compliance?**

Email [productcompliance@molex.com](mailto:productcompliance@molex.com)  
 For a multiple part number RoHS Certificate of Compliance, [click here](#)

Please visit the [Contact Us](#) section for any non-product compliance questions.

**Search Parts in this Series**

[5559Series](#)

**Mates With**

[5557d Receptacle Housing](#)

**Use With**

[5558](#) , [44478](#) , [30490](#) , [41995](#)

This document was generated on 06/08/2010

**PLEASE CHECK [WWW.MOLEX.COM](http://WWW.MOLEX.COM) FOR LATEST PART INFORMATION**

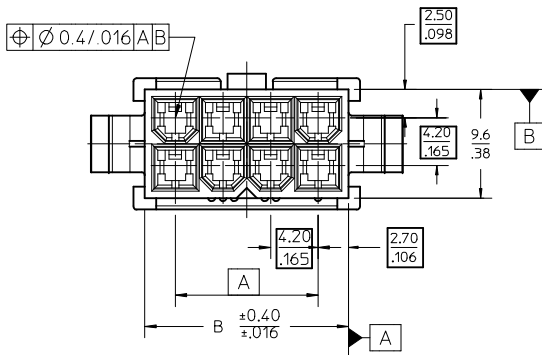
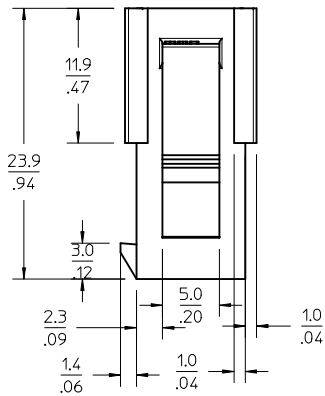
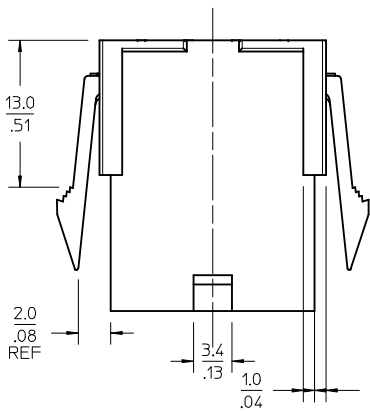
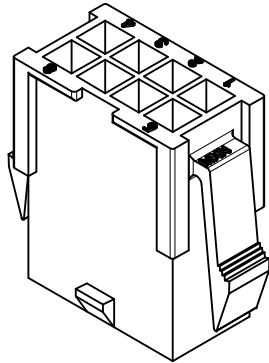
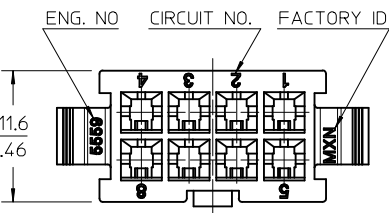

NOTES:

- 1) MATERIAL:
  - \*BLANK\* = NYLON 6/6, 94V-2, COLOR: NATURAL.
  - \*BL\* = NYLON 6/6, 94V-2, COLOR: BLACK.
  - \*BU\* = NYLON 6/6, 94V-2, COLOR: BLUE.
  - \*RE\* = NYLON 6/6, 94V-2, COLOR: RED.
  - \*210\* = NYLON 6/6, 94V-0, COLOR: NATURAL.
- 2) FINISH: NOT APPLICABLE
- 3) PRODUCT SPECIFICATION: PS-5556-001
- 4) PACKAGING: BULK
- 5) PART MATES WITH MOLEX RECEPTACLE #5557.
- 6) PART IS TO BE USED WITH MOLEX FEMALE TERMINAL #5558.
- 7) PART IS NOT DESIGNED FOR CURRENT SHARING.
- 8) CONNECTORS ARE NOT TO BE MATED OR UNMATED WHILE CIRCUITS ARE LIVE.
- 9) WIRES ARE TO BE DRESSED IN SUCH A MANNER TO ALLOW THE TERMINALS TO FLOAT FREELY IN THE POCKET.
- 10) PART CONFORMS TO CLASS "B" REQUIREMENTS OF COSMETIC SPECIFICATION PS-45499-002 WITH THE EXCEPTION OF DISCOLORATION, FLASH AND SINK MEET CLASS "C" REQUIREMENTS.
- 11) ON 2 CIRCUITS PARTS THIS DIMENSION IS ALLOWABLE UP TO "D" DIMENSION.
- 12) PANEL HOLE TO BE PUNCHED OUT IN THE SAME DIRECTION AS INSERTION INTO THE PANEL.

LEGEND

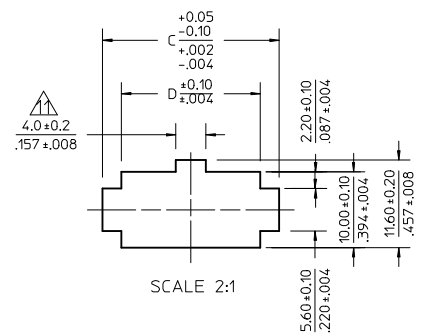
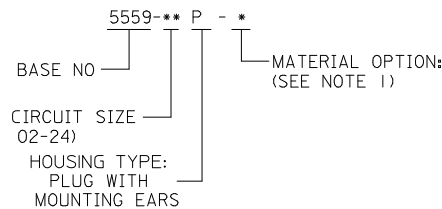

RECOMMENDED PANEL HOLE DIMENSIONS  
(THICKNESS : 0.8-2.0/.032-.079)

52.1/2.051	57.0/2.244	51.6/2.031	46.2/1.819	24
47.9/1.886	52.8/2.079	47.4/1.866	42.0/1.654	22
43.7/1.720	48.6/1.913	43.2/1.701	37.8/1.488	20
39.5/1.555	44.4/1.748	39.0/1.535	33.6/1.323	18
35.3/1.390	40.2/1.583	34.8/1.370	29.4/1.158	16
31.1/1.224	36.0/1.417	30.6/1.205	25.2/0.992	14
26.8/1.055	31.8/1.252	26.4/1.039	21.0/0.827	12
22.6/0.890	27.6/1.087	22.2/0.874	16.8/0.661	10
18.4/0.724	23.4/0.921	18.0/0.709	12.6/0.496	8
14.2/0.559	19.2/0.756	13.8/0.543	8.4/0.331	6
10.0/0.394	15.0/0.591	9.6/0.378	4.2/0.165	4
5.8/0.228	10.8/0.425	5.4/0.213	---	2
	D	C	B	A

<b>ADDED MODEL VIEWS</b> EC NO: UCP2010-0850 DRWN: JAGUILAR 2009/11/09 CHKD: J.BELL 2009/11/10 APPR: F.SMITH 2009/11/10	QUALITY SYMBOLS ∇=0 ∇=0 ∇=0	GENERAL TOLERANCES (UNLESS SPECIFIED)	DIMENSION STYLE <b>MM/IN</b>	SCALE <b>3:1</b>	DESIGN UNITS <b>METRIC</b>	THIRD ANGLE PROJECTION
		4 PLACES ± --- ± --- 3 PLACES ± --- ± .012 2 PLACES ± .30 ± .016 1 PLACE ± .40 ± ---	DRAWN BY H.HIRAMOTO	DATE 1988/10/14	TITLE <b>NEW MINI. FIT CONNECTOR CRIMP PIN HOUSING</b>	
		ANGULAR ± 3 °	CHECKED BY Y. YAMADA	DATE 1988/10/21	APPROVED BY M.ENOMOTO	DATE 1988/10/24
		DRAFT WHERE APPLICABLE MUST REMAIN WITHIN DIMENSIONS	MATERIAL NO. <b>SEE CHART</b>	DOCUMENT NO. <b>SD-5559-NP</b>	SHEET NO. <b>1 OF 2</b>	

THIS DRAWING CONTAINS INFORMATION THAT IS PROPRIETARY TO MOLEX INCORPORATED AND SHOULD NOT BE USED WITHOUT WRITTEN PERMISSION

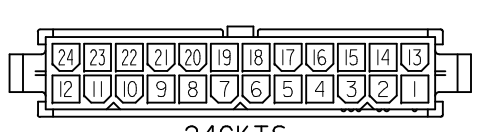
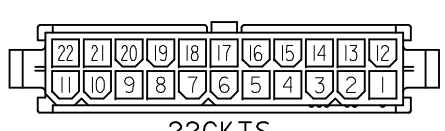
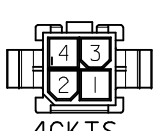
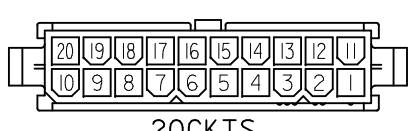
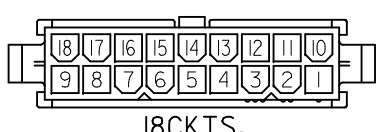
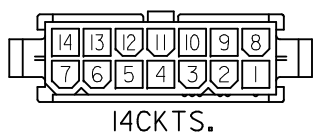
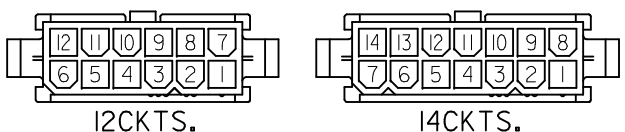

CIRCUIT SIZE LAYOUT (SCALE : 2-1)

V-2 BLACK		
		24
		22
		20
		18
		16
		14
		12
		10
		8
39-02-8065	5569-06P-BL	6
39-02-8045	5569-04P-BL	4
		2
EDP NO.	ENG. NO.	CIRCUIT

V-2 BLUE			V-2 RED			V-0 NATURAL			V-2 NATURAL		
		24			24	39-01-2246	5559-24P-210	24	39-01-2241	5559-24P	24
		22			22	↑ -2226	↑ -22P-210	22	↑ -2221	↑ -22P	22
		20			20	↑ -2206	↑ -20P-210	20	↑ -2201	↑ -20P	20
		18			18	↑ -2186	↑ -18P-210	18	↑ -2181	↑ -18P	18
		16			16	↑ -2166	↑ -16P-210	16	↑ -2161	↑ -16P	16
		14			14	↑ -2146	↑ -14P-210	14	↑ -2141	↑ -14P	14
		12			12	↑ -2126	↑ -12P-210	12	↑ -2121	↑ -12P	12
		10			10	↑ -2106	↑ -10P-210	10	↑ -2101	↑ -10P	10
		8			8	↑ -2086	↑ -08P-210	8	↑ -2081	↑ -08P	8
		6	39-02-8067	5559-06P-RE	6	↑ -2066	↑ -06P-210	6	↑ -2061	↑ -06P	6
		4	39-02-8047	5559-04P-RE	4	↑ -2046	↑ -04P-210	4	↑ -2041	↑ -04P	4
		2			2	39-01-2026	5559-02P-210	2	39-01-2021	5559-02P	2
EDP NO.	ENG. NO.	CIRCUIT	EDP NO.	ENG. NO.	CIRCUIT	EDP NO.	ENG. NO.	CIRCUIT	EDP NO.	ENG. NO.	CIRCUIT

<b>SEE SHEET 1</b> EC NO: UCP2010-0850 DRWN: JAGUILAR 2009/11/09 CHKD: BELL 2009/11/10 APPR: F. SMITH 2009/11/10	QUALITY SYMBOLS ▽=0 ▽=0 ▽=0	GENERAL TOLERANCES (UNLESS SPECIFIED) mm INCH 4 PLACES ± --- ± --- 3 PLACES ± --- ± .012 2 PLACES ± .30 ± .016 1 PLACE ± .40 ± --- ANGULAR ± 3°	DIMENSION STYLE MM/IN DRAWN BY DATE H. HIRAMOTO 1988/10/14 CHECKED BY DATE Y. YAMADA 1988/10/21 APPROVED BY DATE M. ENOMOTO 1988/10/24	SCALE DESIGN UNITS 2:1 METRIC THIRD ANGLE PROJECTION
	NEW MINI. FIT CONNECTOR CRIMP PIN HOUSING			
	MOLEX INCORPORATED			
	DRAFT WHERE APPLICABLE MUST REMAIN WITHIN DIMENSIONS			SEE CHART MATERIAL NO. SD-5559-NP SHEET NO. 2 OF 2

THIS DRAWING CONTAINS INFORMATION THAT IS PROPRIETARY TO MOLEX INCORPORATED AND SHOULD NOT BE USED WITHOUT WRITTEN PERMISSION